

# Model 5100 Series Automation Controller Quick Reference Guide

---

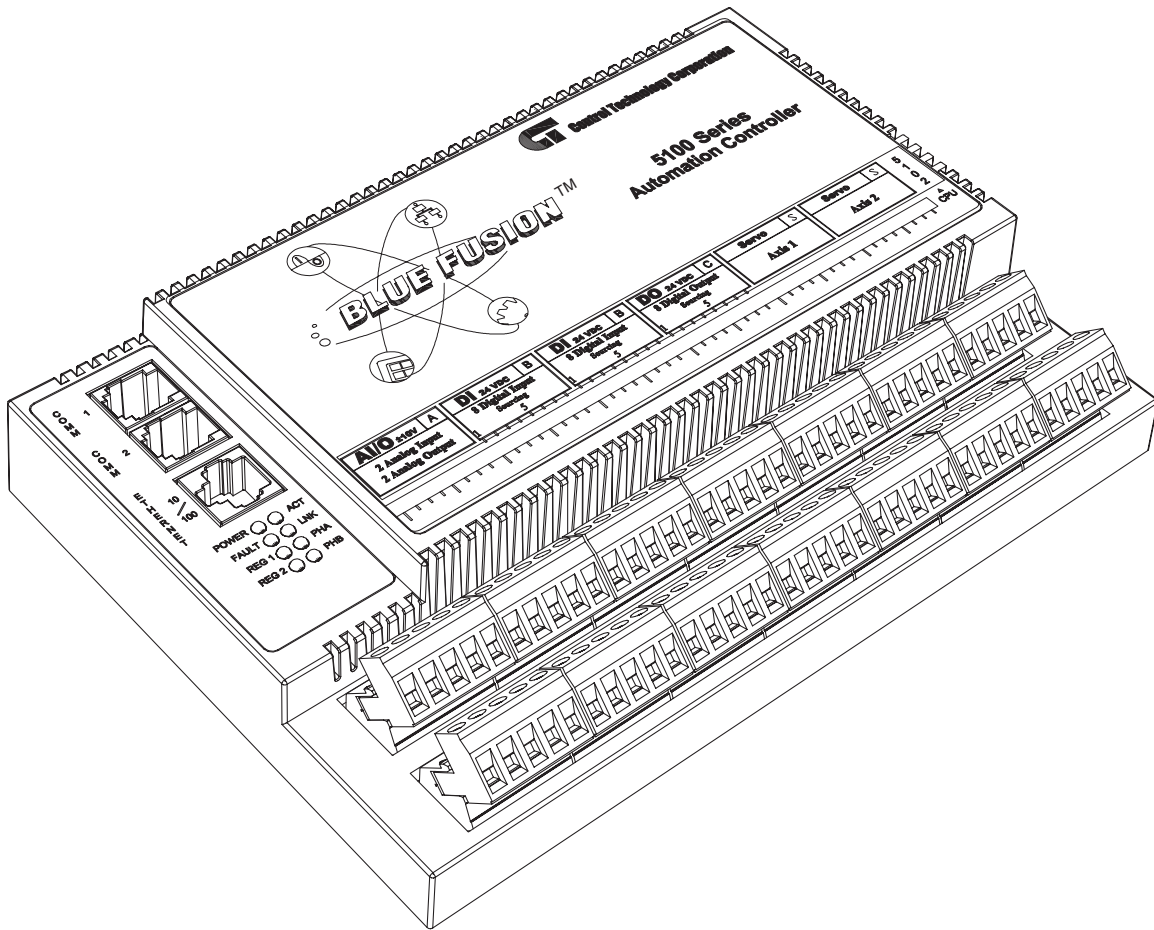

Doc. No. 5100QRG  
Revision C  
October 2007

---

The information in this document is subject to change without notice. The software described in this document is provided under license agreement and may be used or copied only in accordance with the terms of the license agreement.

The information, drawings, and illustrations contained herein are the property of Control Technology Corporation. No part of this manual may be reproduced or distributed by any means, electronic or mechanical, for any purpose other than the purchaser's personal use, without the express written consent of Control Technology Corporation.

The following are trademarks of Control Technology Corporation:

- Quickstep
- CTC Monitor
- CTC Utilities

Windows is a trademark of Microsoft Corporation.

# Contents

---

- Product Overview ..... 5
- Model 5100 Quick Reference Guide ..... 5
- Wiring Diagrams ..... 8
- Controller Specifications ..... 10
- Hardware / Firmware Revision Levels ..... 13

This page is intentionally left blank.

# Model 5100 Quick Reference Guide

## Product Overview

This section shows the Model 5100's dimensions and provides details about its faceplate.

Figure 1. Model 5100 Dimensions (1 of 2)

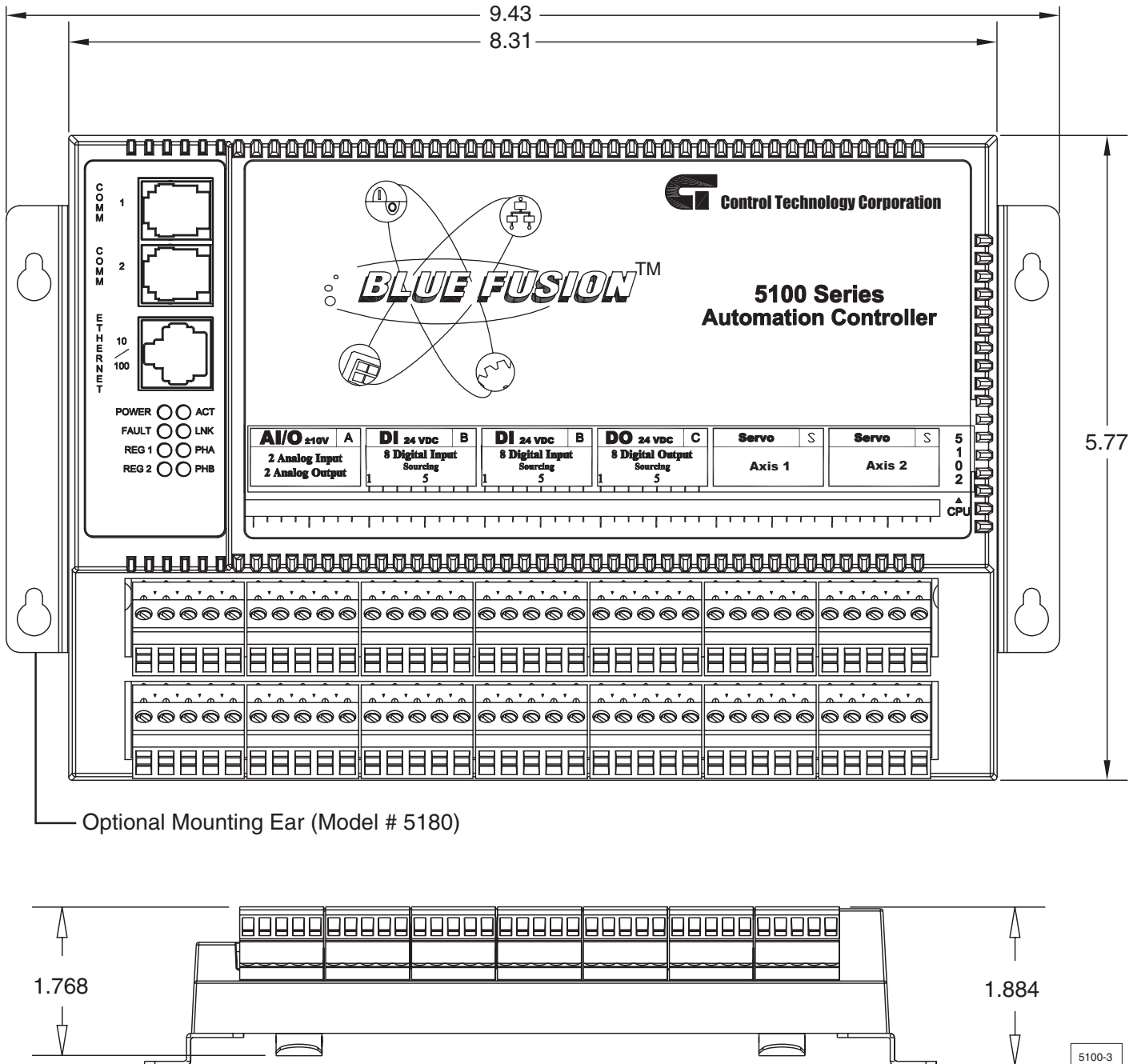

Model 5100 Quick Reference Guide  
Product Overview

Figure 2. Model 5100 Dimensions (2 of 2)

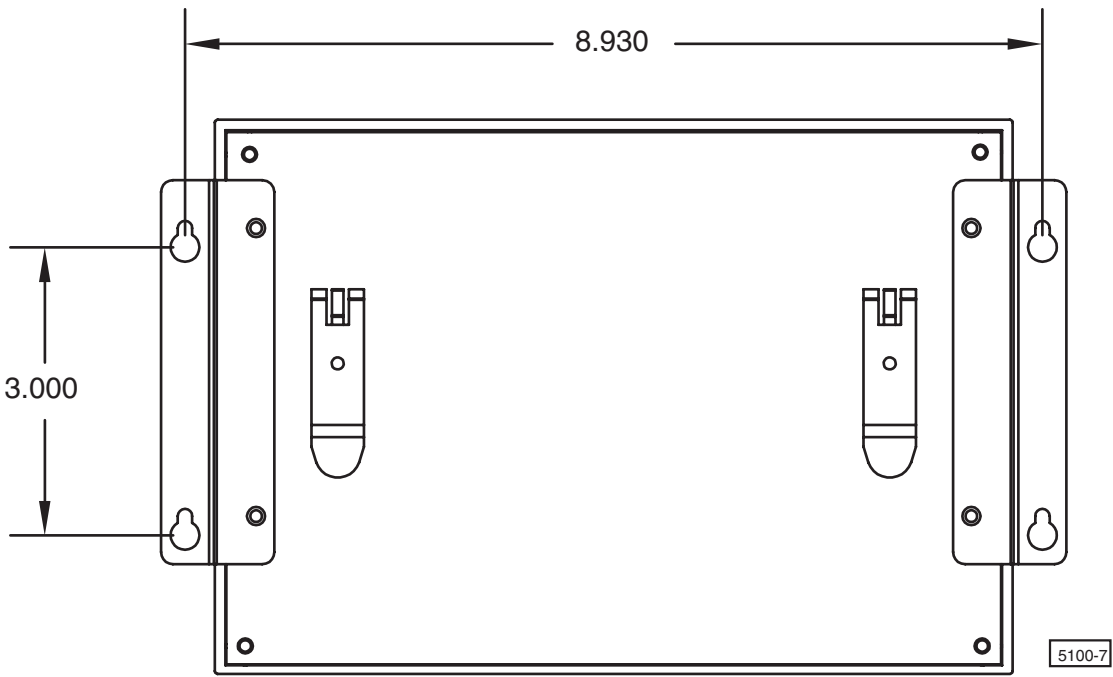
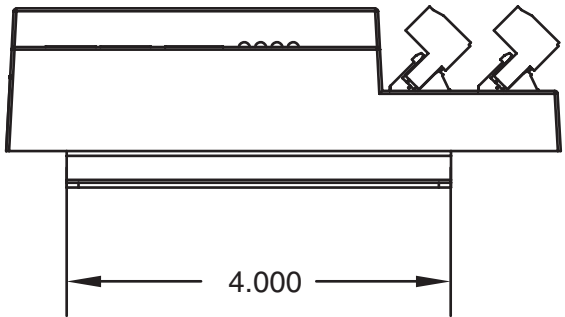

**Model 5100 Quick Reference Guide**  
**Product Overview**

**Figure 3. Model 5100 Faceplate**

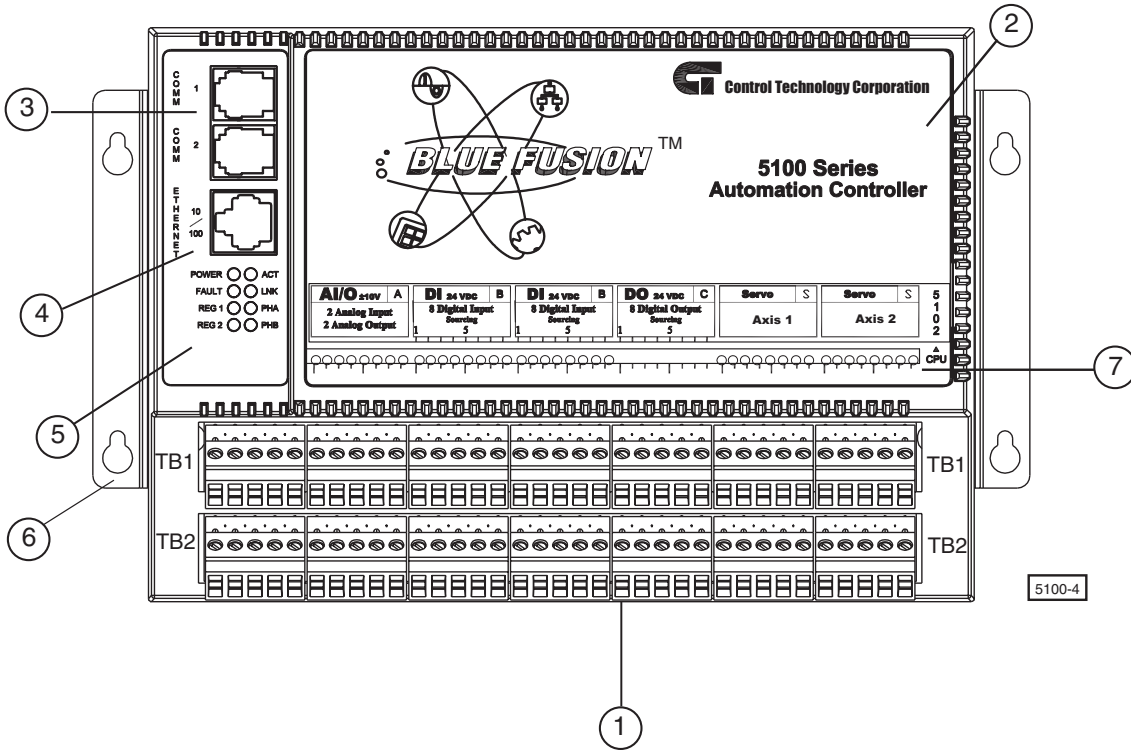

Callout Number	Description
1	<b>Terminal block interface:</b> Removable terminal blocks connect to the controller's internal module bays and eliminate the need for cables and breakout blocks. The top terminal block is TB1 and the bottom block is TB2 for each location.
2	<b>Internal module bays:</b> There are 6 internal module bays that can hold any combination of I/O and Motion Control modules. I/O modules occupy 1 bay and Motion Control modules occupy 2 bays.
3	<b>Dual RS-232 ports:</b> Provides both programming and data communications with a PC by using Quickstep and CTCMON; compatible with CTC's 2881-2883 communications cables and with the cable supplied with Quickstep. Refer to the RS-232 pinout diagram in <i>Wiring Diagrams</i> for more information.
4	<b>10/100Base-T connector:</b> Provides Ethernet communications and contains auto-sensing circuitry that automatically detects the speed of an Ethernet network when a cable is plugged into it.
5	<b>CPU status LEDs:</b> Provide quick diagnostics for the master encoder, Ethernet, and high-speed inputs; indicate when power is applied to the controller; display a hardware or software fault.
6	<b>Optional Mounting Ear (Model # 5180):</b> Alternative method of mounting the controller that allows you to install the controller on a flat surface such as a NEMA-rated enclosure.
7	<b>Module I/O status LEDs:</b> Provide visual I/O indicators at each connection point.

# Wiring Diagrams

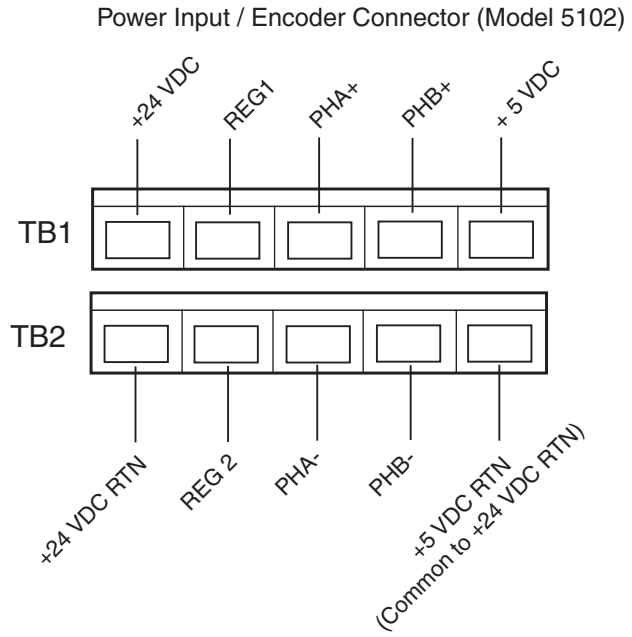
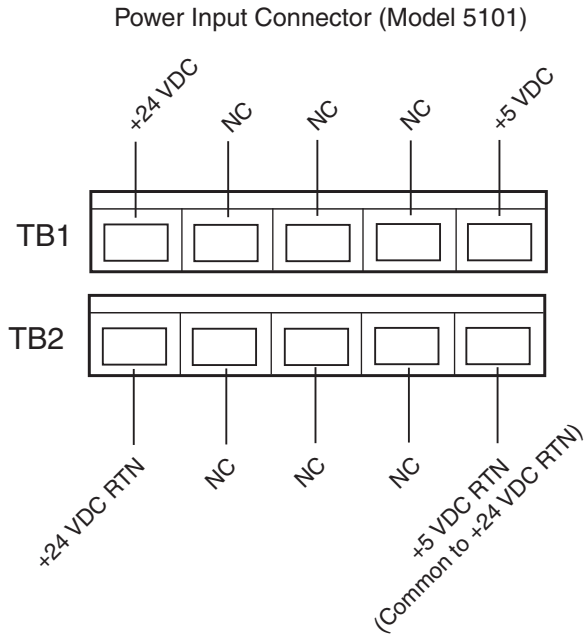
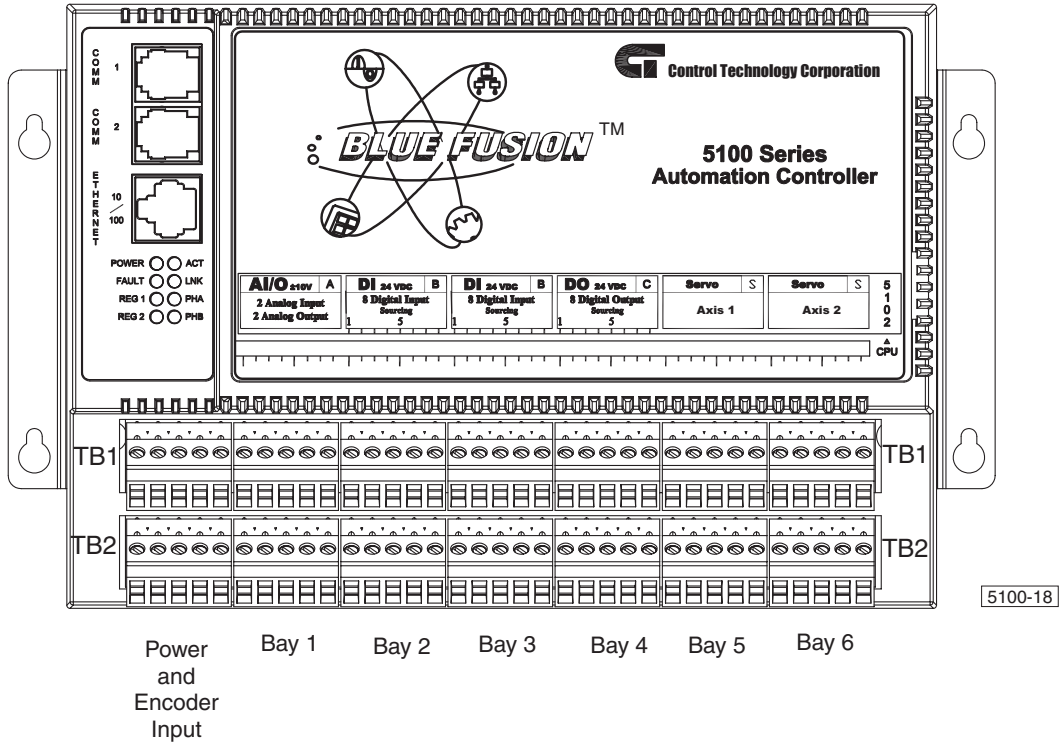



### Power Input Connections (Model 5101)

Signal Name	LED Name	Terminal Block #	Signal Name	LED Name	Terminal Block #
+24 VDC		TB1-1	NC		TB2-3
+24 VDC Return		TB2-1	NC		TB1-4
NC		TB1-2	NC		TB2-4
NC		TB2-2	NC		TB1-5
NC		TB1-3	NC		TB2-5

### Power Input / Encoder Connections (Model 5102)

Signal Name	LED Name	Terminal Block #	Signal Name	LED Name	Terminal Block #
+24 VDC		TB1-1	PHA-	PHA	TB2-3
+24 VDC Return		TB2-1	PHB+	PHB	TB1-4
REG1	REG 1	TB1-2	PHB-	PHB	TB2-4
REG2	REG 2	TB2-2	+5 VDC		TB1-5
PHA+	PHA	TB1-3	+5 VDC Return		TB2-5

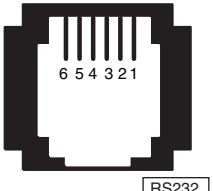
RS-232 Drawing	Pin #	Signal
	1	Not Used
	2	TxD Outbound
	3	Common
	4	Common
	5	RxD Outbound
	6	Common

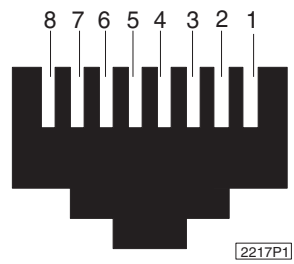
10/100Base-T Connector	Pin #	Signal
	1	TX0+
	2	TX0-
	3	RX1+
	4	NC
	5	NC
	6	RX1-
	7	NC
	8	NC



#### Note

Model 51xx controllers ship with a default IP address of 192.168.1.51.

## Controller Specifications



### Note

All specifications are at 25°C unless otherwise specified.

Description	Min.	Typical	Max.	Units
<b>Absolute Maximum Ratings</b>				
Ambient Temperature				
Operating	0		+50	°C
Storage	-20		+80	°C
Applied input voltage	18.0	24.0	27.0	VDC
Applied output voltage	0		24.0	VDC
Current requirement (5 V)		0.4	0.6	A
<b>Digital Input Specifications</b>				
Input off voltage ( $I_i = 0$ mA)	0			VDC
Input on current ( $V_i = 24$ V) <sup>1</sup>		1.2	1.5	mA DC
Input on current threshold ( $V_i = 16$ V typical)		.8	.9	mA DC
Input off current (typical leakage current allowable)			250	μA DC
<b>Digital Output Specifications</b>				
Output on voltage ( $I_o = 350$ mA) <sup>2</sup>		22.8	23.0	VDC
Output current			350	mA DC
Total limit per controller			3	A DC
Output off leakage (applied voltage = 24 VDC) <sup>3</sup>		1.0	100.0	μA DC
<b>Analog Input Specifications</b>				
Differential input range (full scale)	-10.000		+10.000	VDC
Common mode voltage range	-10		+10	VDC
Input resistance	10			MΩ
Input resolution (13-bit)		.0061	.012	%FS
Input accuracy (25°C, 8-sample filtering)		.0061	.012	%FS

1. Under normal operation, no external input voltage is applied. Inputs should be externally switched to the input common.
2. An on-board protection diode returns to +24 V from each output.
3. In the off state, unconnected outputs are internally pulled to +5 V through a diode and an LED indicator.

**Model 5100 Quick Reference Guide  
Controller Specifications**

<b>Description</b>	<b>Min.</b>	<b>Typical</b>	<b>Max.</b>	<b>Units</b>
Input settling time				
1 least significant bit		1.64		ms
-10 V to +10 V			52.5	ms
<b>Analog Output Specifications</b>				
Output voltage range	-10.000		+10.000	VDC
Output resolution		2.44		mV
Output settling time				
-10.000 to +10.000 V			3.28	ms
0 to +5.000 V			1.64	ms
<b>Controller Characteristics</b>				
User memory capacity (4 years unpowered lithium-cell RAM)		128K		Bytes
<i>The main CPU is an Hitachi SH2 processor running at 24.576 MHz.</i>				
<b>Communications Characteristics</b>				
RS-232 transmitters		± 5	± 10	VDC
RS-232 receivers	± 3		± 10	VDC
Common mode voltage range	-10		+10	VDC
Ethernet Transceivers (10/100 Megabits/sec) <sup>4</sup>			1.5	VAC PP
<b>Encoder Specifications</b>				
Encoder supply voltage	0.0	5.0	5.25	VDC
Encoder supply output current			150	mA
Differential encoder input				
Nominal input range	0.0	5.0		VDC
Open circuit voltage ( $I_i = 0$ mA)		5.0	5.38	VDC
Logic low current ( $V_i = 0$ V)		1.1	1.2	mA
Maximum on-board data rate			3	MHz
4. This conforms to IEEE Standard 802.3.				

**Model 5100 Quick Reference Guide**  
**Controller Specifications**

Description	Min.	Typical	Max.	Units
<b>Registration Input Specifications</b>				
Off voltage ( $I_i = 0$ mA)		0		VDC
On current ( $V_i = 24$ V)		1.2		mA
Threshold				
low-to-high		16		VDC
high-to-low		15		VDC
<b>Servo Specifications</b> <sup>5</sup>				
Command outputs				
Nominal voltage range	-10		+10.0	VDC
Resolution (16-bit)		305		$\mu$ V
Maximum velocity setting	1		6,000,000	pulses/s
Resolution of maximum velocity	1			pulses/s
Acceleration and deceleration settings	1		130,000,000	pulses/s <sup>2</sup>
Resolution of acceleration and deceleration settings	1			pulses/s <sup>2</sup>
Position range (absolute mode)	-2,147,483,648		2,147,483,647	steps
Relative motion command range	-2,147,483,648		2,147,483,647	steps
<b>Controller Resource Summary</b>				
Multi-tasking (tasks)			84	
Volatile registers (32-bit)			500	
Non-volatile registers (32-bit)			4500	
Data table elements (16-bit, non-volatile)			16000	
Input-linkable counters			8	
Flags			32	
Program steps			4096	

5. The term *step* refers to one edge transition on either encoder input for that axis.

**Model 5100 Quick Reference Guide  
Controller Specifications**

<b>Description</b>	<b>Min.</b>	<b>Typical</b>	<b>Max.</b>	<b>Units</b>
<b>Controller Capacities (5101) <sup>6</sup></b>				
Module slot capacity			6	
Digital inputs			48	
Digital outputs			48	
Analog inputs			24	
Analog outputs			48	
Servo motor axes			6	
Ethernet ports			1	
RS-232 channels			2	
Master encoders			0	
<b>Controller Capacities (5102) <sup>6</sup></b>				
Module slot capacity			6	
Digital inputs			50	
Digital outputs			48	
Analog inputs			24	
Analog outputs			48	
Servo motor axes			6.5	
Ethernet ports			1	
RS-232 channels			2	
Master encoders			1	

6. Controller capacities are not mutually inclusive. You cannot operate resources at full capacity at the same time.

## Hardware / Firmware Revision Levels

<b>Model Numbers</b>	<b>Hardware Revision Level</b>	<b>Firmware Revision Level <sup>1 2</sup></b>
5100	0 or greater	4.0

- You can confirm firmware revision levels by doing a register read in Quickstep's monitor program. Use register 13003 to confirm the firmware revision in a MultiPro controller.
- Firmware revision levels are not equivalent to standard decimal numbers. For example, firmware revision level 2.10 translates to:

Major Revision Level 2  
Minor Revision Level 10

If this value changes to 2.20, it translates to:

Major Revision Level 2  
Minor Revision Level 20 (not revision level 2)