



Model 2600XM Automation Controller Installation Guide

This document is current as of the following revision levels:

- Controller Firmware - 2.0
- Controller Hardware - C

This guide contains installation and applications information for the model 2600XM Automation Controller. The Model 2600XM has a flexible plug-in architecture, which supports a variety of modules, and comes in two sizes:

- The 2600XM-5, the base model, containing slots for five modules and a plug-in CPU
- The 2600XM-10, containing slots for ten modules and a plug-in CPU

You program the 2600XM controller using CTC's state programming language, Quickstep™ for Windows™. You run all programming and diagnostic functions for the controller using an RS-232 interface, which you can also use as a computer communications port.

This guide is divided into the following sections:

Specifications	2
Dimensions and Mounting Instructions for the Model 2600XM	3
Inserting Modules into the Controller	4
Model 2600XM Power Connections	6
Connecting AC Power	6
Using Step-down or Isolation Transformers	6
The Importance of Proper Grounding	6
The Controller's Power System	7
Using External Power Supplies	7
Status Light Description	8
Setting-up Controller Communications	9
Using the RS-232 Port for Controller Communications	9
Using Ethernet for Controller Communications	11

Specifications

Temperature Ratings	Min	Typ	Max	
Ambient Temperature				
operating	0		50	°C
storage	-20		80	°C
AC Power Supply Requirements	Min	Typ	Max	
AC Voltage Range				
120 Volt mode	90.0	120.0	132	VAC
240 Volt mode	190.0	240.0	264.0	VAC
Current Requirements				
120 Volt mode		0.1	0.9	Amp AC
240 Volt mode		0.05	0.45	Amp AC
Internal Power Supply Capacities	Min	Typ	Max	
+5 Volt Logic Supply				
Current Capability			3.0	Amp DC
CPU Requirement		0.2	0.25	Amp DC
+24 Volt I/O Supply				
Current Capability (continuous)			1.5	Amp DC
Controller Resource Summary				
Multi-Tasking (number of tasks)	28			
Volatile Registers (32-bit)	488			
Non-Volatile Registers (32-bit)	500			
Data Table Elements (16-bit, Nonvolatile)	8000			
Input-linkable Counters	8			
Flags	32			
Program Steps	1024			
Controller Capacities *	2600XM-5	2600XM-10		
Module Slot Capacity	5	10		
Inputs	128	320		
Outputs	120	320		
Analog Inputs	64	160		
Analog Outputs	40	80		
Thumbwheels				
4-digit	16	16		
8-digit	8	8		
Numeric Displays				
4-digit	16	16		
8-digit	8	8		
Stepping Motor Axes	5	10		
Servo Motor Axes	10	16		
Relay Outputs	40	80		
RS-232 Channels	1	1		

For controller performance specifications and information on individual modules, refer to their respective data sheets and installation and applications guides.

* Not mutually inclusive.

Dimensions and Mounting Instructions for the Model 2600XM

The Model 2600XM Automation Controller is provided with mounting ears, allowing them to be easily mounted to a flat surface (for example, an NEMA-rated electrical enclosure) with four mounting bolts. You should follow the guidelines described in this installation guide to ensure a successful design.

Mounting Considerations

When selecting a mounting location for the controller, care should be taken to provide protection against various environmental factors:

- The controller should not be exposed to flying metal chips (be careful during installation and subsequent machine construction work!), conductive dusts, liquids or condensing humidity. In environments where these hazards may be present, the controller should be housed in a NEMA 4 or NEMA 12 rated enclosure, as appropriate.
- The controller is not intended for mounting in an environment requiring explosion-proof practices.
- If possible, the controller should be mounted physically distant from devices producing Electromagnetic Interference (EMI) or Radio Frequency Interference (RFI). This includes motor starters, relays, large power transformers, ultrasonic welding apparatus, etc.

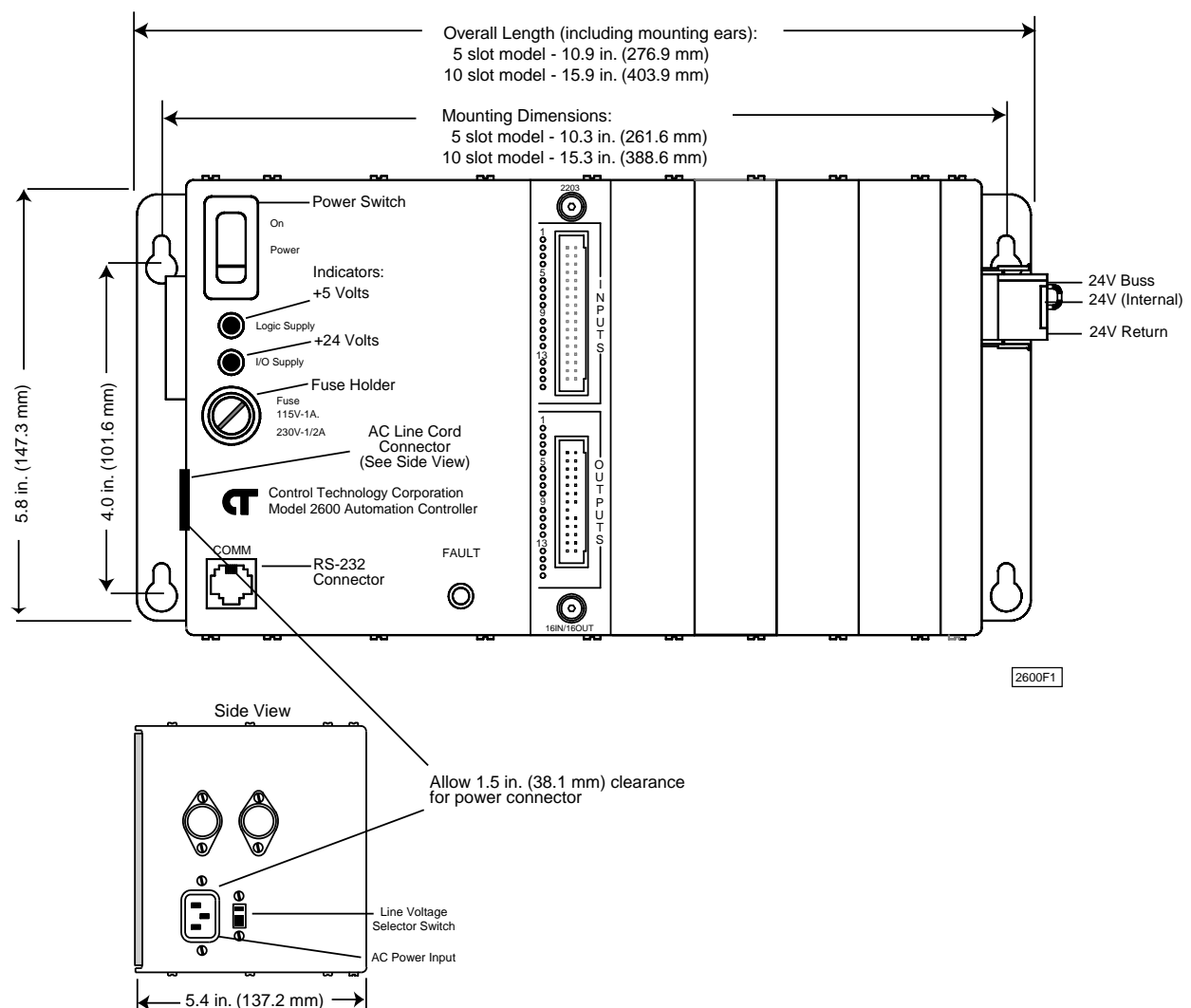

Inserting Modules into the Controller

The Model 2600XM controller accepts a variety of plug-in modules. You insert the modules into one of the slots of your Model 2600XM controller. Any combination of modules, subject to system limits, may be inserted into the controller.

You may insert modules in any order; the controller's CPU dynamically assigns motor number, input number, output numbers, etc., each time power is reapplied to the controller. These numbers are assigned from left to right across the controller, from slot one to slot ten in a Model 2600XM-10.

To install a module into the controller:

1. Remove all AC and DC power to the controller. This includes any external power supplies connected to the controller.
2. Remove the retaining screws from the top and bottom of the cover plate at the location where you are inserting the new module. Save these screws to reinstall the new module.
3. To orient the module properly, make sure the labeling on the module reads right-side up. See illustration on page 2.
4. Slide the module into the slot, insuring that the circuit board slides into the nylon guides at the top and bottom of the slot.
5. Press the module firmly into the controller. When properly seated, the faceplate of the module is flush with the adjacent sheet metal surface.
6. Reinstall the retaining screws in the top and bottom of the new module.
7. Wire the module according to the instructions in its installation guide.

Inserting Modules into the Controller

Some modules provide one or more connectors on their faceplates. To keep their wires from becoming accidentally unplugged and from tangling together, CTC manufactures a bracket to hold the wires. The Model 2699 bracket attaches to the controller as shown below. Once the bracket is installed, you can attach connector wires to it.

1. Remove the retaining screws from the top of the module. Save these screws to secure the bracket.
 2. Place the bracket on the controller, making sure you line up the holes on the bracket with the holes for the retaining screws.
 3. Reinstall the retaining screws.
 4. Wire the module according to the instructions in its installation guide.
 5. Use tywraps to fasten the wires to the holes in the bracket.
-

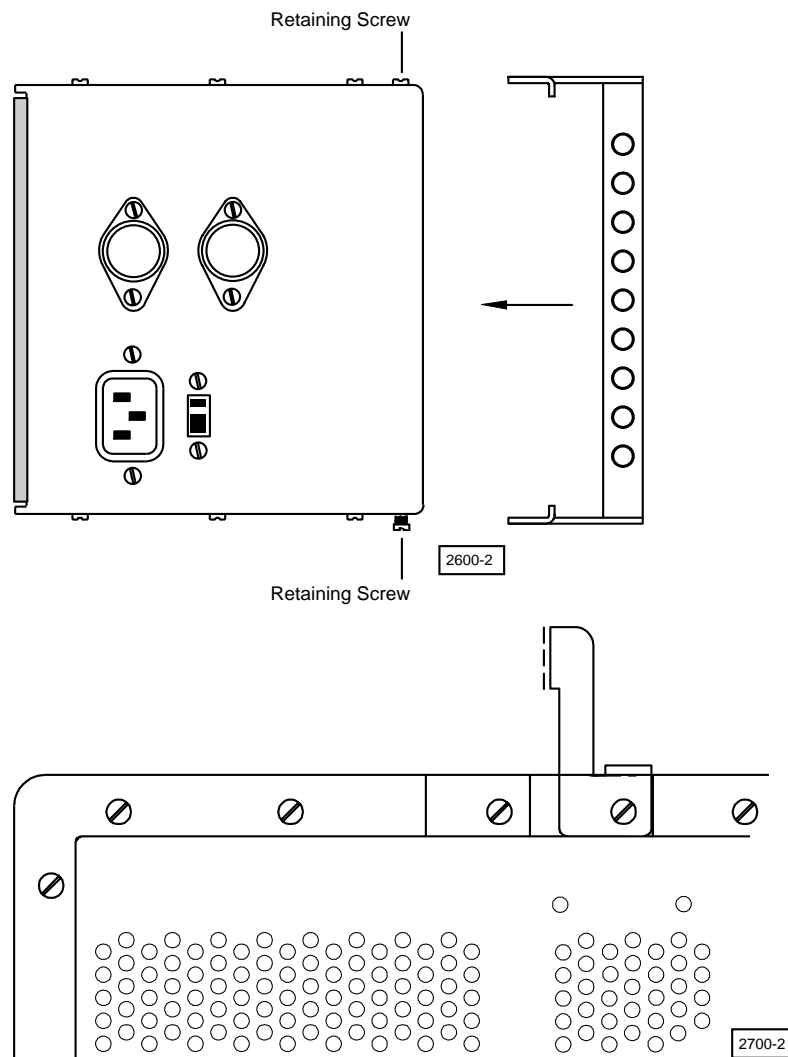

The Model 2699 bracket requires an additional 2 in of clearance for the front of the controller.

Model 2600XM Power Connections

Connecting AC Power

The Model 2600XM contains an internal power supply which provides two mutually-isolated voltages (+5 VDC and +24 VDC) for the operation of the controller. Also included are two LED indicators for these voltages and a power ON-OFF switch.

The controller's power supply requires AC power, either 120 VAC or 240 VAC nominal for proper operation. Power is applied to the controller via the standard IEC-type power connector on the side of the controller. A US-standard three-prong power cord is provided with the controller for this purpose.

The supply voltage required is determined by a voltage selector on the side of the unit (see diagram below). A fuse of the appropriate rating must also be installed in the fuse holder on the front of the controller.

Voltage	Range	Fuse
120 VAC	90-132	1 Amp
240 VAC	190-264	1/2 Amp

Using Step-down or Isolation Transformers

When using a step-down or isolation transformer to supply power to the controller, be aware of the following potential issues, all of which are drawn from experience:

- Step-down transformers are typically derive 120 VAC from much higher voltage lines that are also being used to power heavy equipment. Often, when motors are first energized in heavy equipment, the stall currents that result can cause the voltage supplied to the step-down transformer to drop by as much as 50%. Because step-down transformers are ratio-metric devices, the voltage supplied to the controller drops proportionately, causing a potential system malfunction.
- The relatively light load imposed by the controller on the transformer secondary may result in excessive voltage being present, representing a potential hazard to the system.
- Neither type of transformer represents ideal protection against electrical noise. Inter-winding capacitances can result in noise transference among windings, and differential noise may still be electromagnetically coupled to the secondary.
- Adequate grounding of the controller is still critical to its proper performance. For more information, see the section on *The Importance of Proper Grounding*.

These issues often point to the use of an independent power feed (120 or 240 VAC) for the controller and associated components. The resulting additional stability and design integrity are often well worth the slight additional cost.

The Importance of Proper Grounding

The controller is outfitted with an integral line filter to protect against electrical noise carried on the AC power line. This line filter, along with the shielding provided by the controller enclosure itself, depend on the presence of a good ground connection for effectiveness. This is normally accomplished by connecting the controller's power cord to a well-grounded outlet.

As with any electronic equipment, the controller's ground should follow a direct, low-impedance path to the plant's power source. If possible, this path should not be shared by any machinery which injects a large amount of electrical noise into the ground.

In instances where step-down or isolation transformers are being used to power the controller, the ground connection should still be made directly to the controller.

For further consideration regarding noise protection, refer to the Application Note, *Reducing Noise Susceptibility*. Application notes may be obtained at no charge from your distributor or directly from CTC.

The Controller's Power System

The controller's power system provides two operating voltages, electrically isolated from one another:

- **+5 VDC:** Powers the controller's internal circuitry, including the CPU and the logic-level circuitry on the various modules.
- **+24 VDC:** Available with a current capacity of up to 1.0 Amp (maximum), to power external control devices, such as solenoid valves, relays, sensors. You can also use this power supply with some modules to power circuitry on the outbound side of any on-board isolation.

The +5 V supply is not usually made available at any of the module connectors.

NOTE: Do not make any external connections to either the +5 V power supply or its common, as an increased susceptibility to electrical noise may result.

Using External Power Supplies

Many of the modules available for this series of controllers allow the use of an external power supply for powering actuators and other devices, in place of using the controller's +24 V supply. The individual installation guides for these modules provide additional details in this regard.

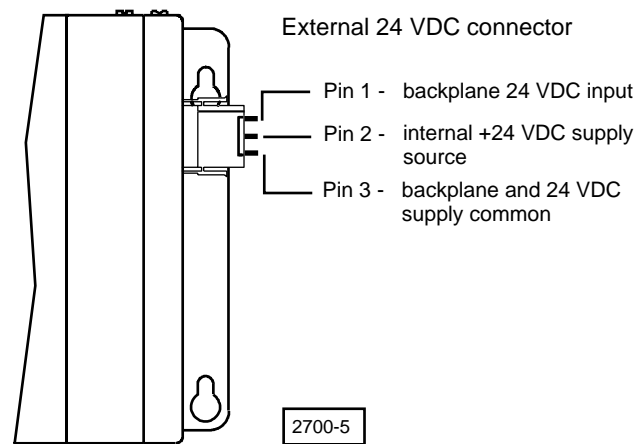

It is possible to connect an external +24 V power supply (with a capacity not in excess of 10 Amps) to the controller's backplane, taking the place of the controller's internal +24 V supply. A nylon 3-pin connector is provided on the side of the controller for this purpose. This connector, as supplied by CTC, is fitted with a mating plug wired with a jumper. The jumper carries +24 V from the internal power supply to the I/O power bus extending across the controller's backplane.

If you remove the jumper plug, you may use the connector to attach an external power supply to the I/O power bus and to the I/O common, pins 1 and 3. An extra mating connector with pins is included with each controller, or you can order a plug with a pigtail wires (Model 2885) from CTC for this purpose.

WARNING: Do not connect an external supply with a voltage rating other than +24 V to this connector, as potential incompatibilities may exist with the modules installed in the controller. Consult CTC for further information.

Status Light Description

The status light on the Model 2600XM can indicate one of the following conditions:

- **Software fault:** A periodic flashing light on the 2600XM indicates a program software fault. This means the controller was unable to execute due to an application problem within the program. To determine what type of software fault has occurred, you can view the program status using Quickstep for Windows' program monitoring utility, CTCMON.

If a program software fault occurs, the controller is idle and all setable resources, such as outputs, registers or flags, are left in the state they were in prior to the software fault. You can program register 13009 to turn off a specific output in the event of a software fault. Refer to the list of special purpose registers for more information.

- **Hardware fault:** A steady red light indicates that the internal watch dog timer has disabled the controller's CPU. If this occurs, the controller's outputs are also disabled. Try cycling the power, re-downloading your Quickstep program, or both. If the fault continues, your controller may have to be returned to Control Technology Corp. for repair. For further details, contact our Technical Support department before returning your controller.

When powering-up the controller, the status light is a steady red light during the first second of operation.

Setting-up Controller Communications

Your controller can be set up to communicate with a computer or with other controllers through an RS-232 port or on an Ethernet network.

Using the RS-232 Port for Controller Communications

The RS-232 port on your Model 2600XM controller provides a means for both programming and data communications via a personal computer using Quickstep. The controller is also equipped with a built-in protocol allowing direct computer communications with the controller's RS-232 port. This protocol is described in the *Guide to CTC Serial Data Communications* available in the customer section of our web site. It allows an external computer to directly interact with many of the controller's resources such as, counters, registers, I/O, flags, without modifying the controller's program.

You can also use RS-232 communications when monitoring a controller using CTCMON.

RS-232 Connections

Connections to the controller's RS-232 port is made via a modular jack on the controller (labelled COMM). This jack carries the receive signal, two commons (ground), and the transmit signal for the communications channel. The pin connection diagram illustrates the wiring of the jack. Only the center four connectors of a six- or eight-conductor jack are used.

A series of standard CTC cables are available for making connections to this jack. See the illustrations below and on the following page. As an alternative, many commonly-available telephone cables may be substituted.

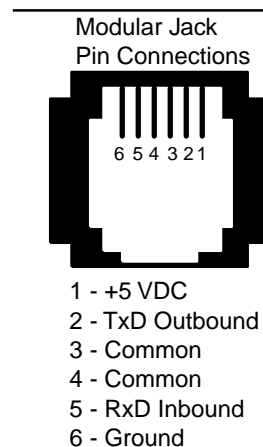

2600P1

NOTE: Do not connect the controller to a telephone line.

Connecting to a D Connector

RS-232 ports on computers are frequently brought out through 25- or 9-pin D type connectors. There is a standard for wiring such connectors followed by most PC manufacturers.

Personal computer with RS-232 asynchronous communications board

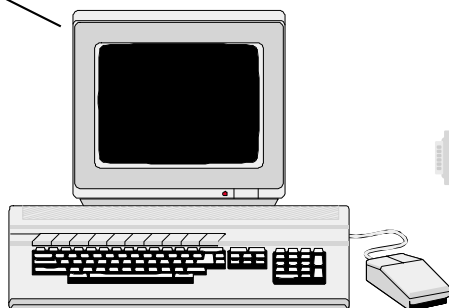

Communications cable:
Model 2881 - 5 feet
Model 2882 - 15 feet
Model 2883 - 25 feet

D-connector to modular Jack adapter:
Model 2280A for 25-pin D-connectors
Model 2280B for 9-pin D-connectors

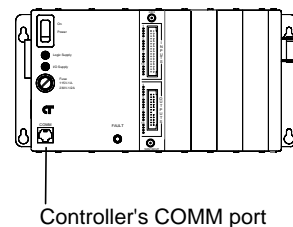

Controller's COMM port

2600-3

Setting-up Controller Communications

Control tech has adapters available that connect directly to a male 25-pin (Model 2880A) or 9-pin (2880B) D connector. These adapters provide a modular jack wired for compatibility with the COMM port. To be fully compatible when using this adapter, the computer's communications port should be wired as a DTE device.

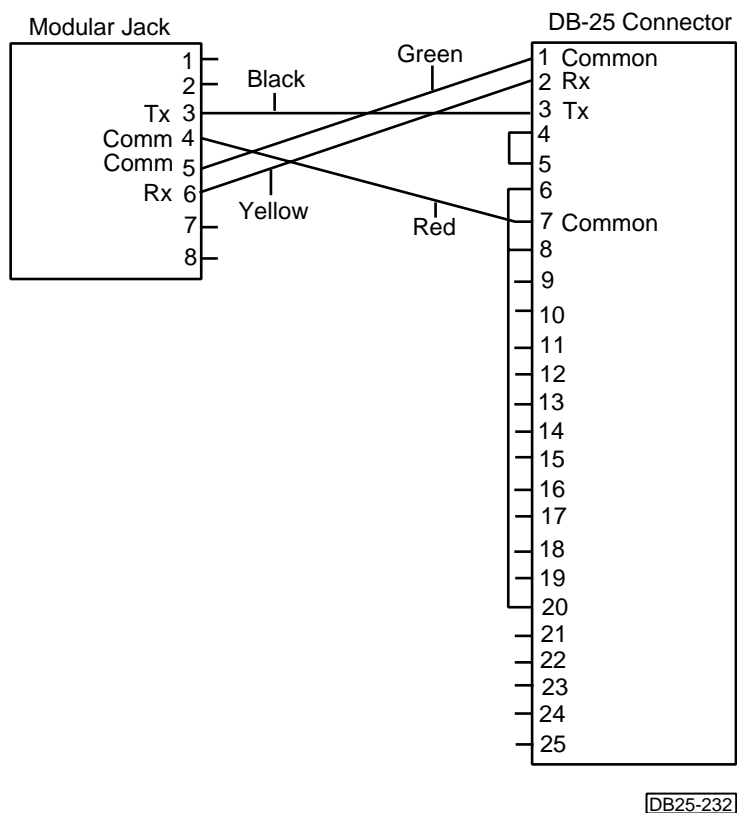
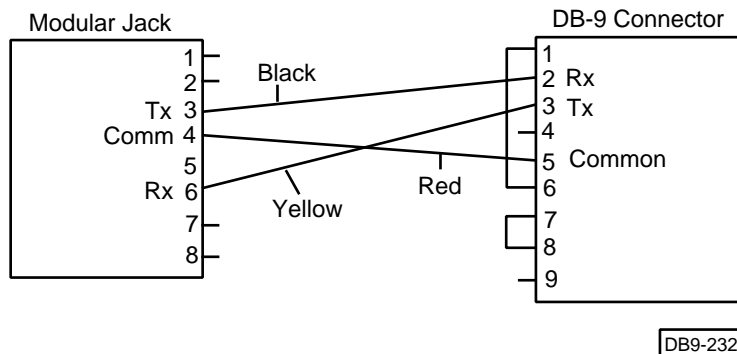

Using Ethernet for Controller Communications

Your 2600XM controller can access an ethernet network for controller-computer communications using a Model 2217 or 2717 Ethernet Module. The 2217 or 2717 contains both 10/100BaseT connections, as well as two RS-232 ports. The connections to the controller Ethernet port use Ethernet IEEE 802.3 standard 10BaseT connections. For additional information about setting up Ethernet communications, refer to the installation and applications guide for the 2217 or 2717 modules.

The following illustration shows computer-controller connections using an Ethernet connection and list the part numbers for 10Base2 connectors.

